



# SAFE ATHLETICS TRACK & FIELD SAFETY GUIDE FOR COMPETITION

(2018) - Supersedes 2017 UKA Safe Code of Practice



# TABLE OF CONTENTS

SAFE ATHLETICS.....	4	<b>THROWS</b>	<b>SAFETY</b>
FOREWORD.....	5	.....	27
WHOSE JOB IS SAFETY?.....	5	SAFETY IN	THROWS
RISK ASSESSMENT .....	6	.....	28
THE IMPORTANCE OF RISK ASSESSMENTS.....	6	THROWING SAFETY ESSENTIALS .....	30
OFFICIALS AND DYNAMIC RISK MANAGEMENT .....	6	SAFETY PROCEDURES FOR HAMMER THROW .....	30
EXAMPLE .....	7	FAQLITY/EQUIPMENT SAFETY .....	30
AN OFFICIAL'S SAFETY ROLE		SAFETY PROCEDURES FOR DISCUS THROW .....	32
AT COMPETITIONS.....	8	FAQLITY/EQUIPMENT SAFETY .....	32
KEY ROLES OF OFFICIALS AT EVENTS .....	8	SAFETY PROCEDURES FOR CLUB THROW.....	34
WARM-UP .....	10	FAQLITY/EQUIPMENT SAFETY .....	34
<b>TRACK SAFETY .....</b>	<b>11</b>	SAFETY PROCEDURES FOR JAVELIN THROW.....	36
SAFETY PROCEDURES FOR TRACK EVENTS.....	12	FAQLITY/EQUIPMENT SAFETY .....	36
THE START .....	12	SAFETY PROCEDURES FOR SHOT PUT.....	38
THE FINISH.....	12	FAQLITY/EQUIPMENT SAFETY .....	38
HURDLES .....	12	<b>INDOOR COMPETITION SAFETY .....</b>	<b>39</b>
STEEPLECHASE.....	13	SAFETY PROCEDURES FOR INDOOR COMPETITION .....	40
<b>STARTING SAFETY .....</b>	<b>14</b>	TRACKS AND RUNWAYS.....	40
SAFETY PROCEDURES FOR STARTERS .....	15	TRACK SURROUNDS (BARRIERS).....	40
GENERAL CONSIDERATIONS .....	15	ATHLETES .....	40
HANDLING A FIREARM.....	15	EQUIPMENT .....	40
GENERAL STARTING GUIDANCE.....	16		
POST USAGE .....	16		
CABLED START INFORMATION SYSTEM.....	16		
WIRELESS START INFORMATION SYSTEM .....	16		
<b>PHOTO FINISH SAFETY .....</b>	<b>17</b>		
SAFETY PROCEDURES FOR PHOTO FINISH .....	18		
FAQLITY/EQUIPMENT SAFETY .....	18		
PHOTO FINISH TOWER.....	18		
TEMPORARY STAND ALONE VIDEO CAMERA			
MOUNTING TRI-POD.....	19		
VIDEO PF EQUIPMENT INSTALLATION .....	19		
AUTOMATIC STARTING DEVICE(S) INSTALLATION .....	19		
RESULTS CLIPS .....	19		
<b>JUMPS SAFETY .....</b>	<b>20</b>		
SAFETY PROCEDURES FOR POLE VAULT .....	21		
FAQLITY/EQUIPMENT SAFETY .....	21		
SAFETY PROCEDURES FOR HIGH JUMP .....	23		
FAQLITY/EQUIPMENT SAFETY .....	23		
SAFETY PROCEDURES FOR LONG & TRIPLE JUMP.....	25		
FAQLITY/EQUIPMENT SAFETY .....	25		

## SAFE ATHLETICS

Track and Field embraces a wide range of disciplines from sprints to endurance, pole vault to long jump and hammer throw to steeplechase. As with any sport, each discipline carries some form of injury risk both for participants and also for those involved in, or affected by, the activity:- coaches, officials, facility staff, media, spectators or the general public.

Safe Athletics is a new initiative developed by UK Athletics and Home Country Athletics Federations that seeks to raise standards of safety within athletics via best practice guidance and information made freely available to anyone involved in its delivery.

Simply put, following the guidance contained within Safe Athletics resources will provide the best opportunity to avoid accidents and injuries and help ensure the safety of everyone involved in our great sport.

Michael Hunt

UKA Facilities and Health & Safety Manager

April 2018

## SAFETY PROCEDURES FOR SPORTSHALL ATHLETICS



Sportshall Athletics is an indoor form of track and field for children between the ages of 4 and 16. It was created by George Bunner MBE to provide a safe and warm environment for young athletes to train during the cold and dark winter months.

Venue and equipment risk assessments for Sportshall athletics can be found by clicking on the link below:

<http://www.sportshall.org/wp-content/uploads/2013/04/Risk-Assessments.pdf>

# SAFETY PROCEDURES FOR INDOOR COMPETITION

The more confined areas generally associated with indoor athletics will require greater attention being paid to the following:

- Uneven, raised and insecure surfaces.
- The placement of equipment.
- The risk of collisions.
- The proximity of walls and ceilings.
- The programming of activities.

The areas below highlight the specific safety checks that should be carried out in addition to those carried out for outdoor competition.

## TRACKS AND RUNWAYS

- • In the case of demountable tracks ensure that the track boards are secure and are set up according to the manufacturers' specifications.
- • Any change of height (e.g. raised runways) should be clearly marked.

## TRACK SURROUNDS (BARRIERS)

- Ensure barriers at the end of the straight are covered with protective foam to prevent direct contact and are secure and that walls are protected where the run off space is limited.
- Ensure that any protrusions from walls do not present a danger to hurdlers or other athletes.

## ATHLETES

- Ensure flag marshals are posted when conflicting activities are taking place.

## EQUIPMENT

- Any moveable equipment and kit must be placed so as not to constitute a hazard to any events or individuals.

# FOREWORD

This is the first edition of Safe Athletics which supersedes the previously published 2007 and 2017 Safe Codes of Practice for Track and Field Athletics.

There are four new Track & Field publications which fall under the Safe Athletics banner:

1. Safe Athletics - Track & Field Safety Guide for Training (To be published Sept 2018)
2. Safe Athletics - Track & Field Safety Guide for Competition
3. Safe Athletics - Track & Field Safety Guide for Facility Operators (To be published Sept 2018)
4. Safe Athletics - Track & Field Safety Guide for Event Organisers (To be published Sept 2018)

Underpinning these new publications is a new online safety resource library providing templates and examples that can be used to support risk management processes.

Whilst track and field activities are not inherently dangerous, substandard facilities and poor supervision during both training and competition can increase the risk of serious injuries and even lead to fatalities. Safe Athletics builds on the foundations laid by the previous UKA Safe Codes of Practice and encourages all those involved in the delivery of athletics to firmly position safety at the heart of everything that they do.

Although the guidance is focused primarily on those who deliver track and field facilities and activities, the behaviour of athletes and participants themselves is a key factor in ensuring that their own health and safety is protected; and it is hoped that facility operators, coaches, officials, volunteers and all those involved in the administration of the sport will help to raise awareness of Safe Athletics publications and communicate key safety messages to all those who participate in the sport.

# WHOSE JOB IS SAFETY?

Safety is everyone's responsibility and whether you are a facility owner, event organiser, official, coach, athlete or spectator; safety should always be the number one priority above all else. Often, this is easier said than done and in all endeavours there is a balance to be struck between risk and reward; and varying perceptions of risk means that this "balance" is sometimes viewed differently by different people.

What is important is that safety decisions that are taken are not made in isolation and that there is consultation with others to ensure that any proposed actions reflect those of a "reasonable person", i.e. the legal requirement.

## THE IMPORTANCE OF RISK ASSESSMENTS

A risk assessment is an important step in protecting everyone who is affected by athletics activities, including facility operators, athletes, spectators, coaches, volunteers and officials. Risk Assessments help to focus in on the risks that really matter – the ones with the potential to cause significant harm.

For athletics competitions the responsibility for safety is shared between the venue (the provision of safe, well maintained facilities and equipment) and the event organiser (the conduct of safe, well managed competition events and activities).

Risk assessment guidance for Event organisers is covered in the “Safe Athletics - Track & Field Safety Guide for Event Organisers”, but in essence the event organiser should:

1. Request facility risk assessments from the host venue and;
2. Carry out competition specific risk assessments which focus on the activities that will form the competition programme. For example for an evening Sprints Festival the Event Organiser would need to conduct risk assessments that considered any potential hazards relating to: track, kerb, starting blocks, movement of athletes/officials, spectators, adequate floodlighting etc

**NOTE:** It is important to ensure that any control measures identified in the risk assessments are in place before the event / activities proceed.

## OFFICIALS AND DYNAMIC RISK MANAGEMENT

For those who officiate on the day of competition there is no requirement to conduct formal, documented risk assessments. However, officials do have a duty of care to ensure that participants do not suffer any unreasonable level of harm.

In order to discharge this duty of care it is important that officials are aware of the need to constantly conduct “dynamic risk assessments” throughout the event.

Dynamic risk management is the continuous assessment and control of risks throughout the duration of the competition and whilst each and every athlete should take on a degree of responsibility for their own safety and wellbeing the overall responsibility lies with those who manage the activity (i.e. the officials).

It is important therefore, that officials ensure that safe practices are followed at all times and, so far as is reasonably practicable, eliminate or reduce all risks to a minimum.

Note: Examples of generic track and field competition risk assessments can be found in the health & safety section of the UKA website.

# INDOOR COMPETITION SAFETY

# SAFETY PROCEDURES FOR SHOT PUT

(INCLUDING SEATED SHOT PUT)

## FACILITY/EQUIPMENT SAFETY

1. A safety cage is not required for the shot put, so it is important that the impact area is roped off to prevent unauthorised spectators, athletes and officials from accessing to the area.
2. Only designated shot put event officials and participating athletes should be within the cordoned area.
3. Event organisers, meeting managers and referees should ensure that Shot Put events are programmed so as not to present a hazard to other events.

BEFORE THE EVENT	WARM-UP	DURING THE EVENT
<ul style="list-style-type: none"> <li>Check all shot before starting warm up and have the field retriever check them each time they return.</li> <li>The meeting manager or organiser should ensure that all personnel who are liable to enter the infield are made aware of all safety considerations.</li> <li>At least two of the event judges should be suitably qualified.</li> <li>If persons who are not suitably qualified are used they must be instructed in the safety procedures before the start of their duties.</li> <li>Officials safety briefing before the commencement of the event - Most accidents that tend to happen to officials during the shot put event are caused by a short lapse in concentration and it is important that both athletes and officials understand that they need to have to a continual awareness of each other's presence.</li> <li>Ensure that there are adequate retrievers and officials to oversee athlete warm up.</li> <li>Prior to the competition (before warm up), all competitors should be made aware of the safety procedures.</li> </ul>	<ul style="list-style-type: none"> <li>Ensure ALL practice throws are performed from within the designated shot put circle; in the direction of the landing sector and under the supervision of a suitably qualified and competent official.</li> <li>Warm-ups need to be well organised. For example having throwers warm up in competition order.</li> <li>During the throw, officials should stand outside the sector lines and face the thrower at all times.</li> <li>When rotational throwers or those using non-traditional techniques are competing the Chief Judge should ensure all officials are within a safe distance from the potential flight of the implements.</li> <li>An event official should retrieve all throws and athletes should not be allowed to retrieve their own shot.</li> <li>Always keep the impact area clear during warm ups.</li> <li>The Shot must only be returned by hand, or by mechanical device.</li> </ul>	<ul style="list-style-type: none"> <li>Ensure ALL competition throws are performed from within the designated shot put circle; in the direction of the landing sector and under the supervision of a suitably qualified and competent official.</li> <li>Officials must stand outside the landing sector during throws and should be positioned a safe distance away from the thrower.</li> <li>Competitors should be called up in 2s or 3s i.e. Number 15 to throw, 27 to get ready, nine to follow etc.</li> <li>The Chief Judge/Event Leader must first check that the circle is clear.</li> <li>Ensure that only qualified officials are allowed forward of the throwing circle.</li> <li>The Chief Judge must stand with the athlete at the entrance to the circle while the athlete takes up their starting position.</li> <li>During the throw, officials should stand outside the sector lines and face the thrower at all times.</li> <li>When rotational throwers or those using non-traditional techniques are competing the Chief Judge should ensure all officials are within a safe distance from the potential flight of the implements.</li> <li>The Shot must only be returned by hand, or by mechanical device.</li> <li>Once the throw has been taken and the measurement recorded the procedure is repeated for each athlete throughout the competition.</li> <li>It is good practice to repair divots in the landing sector.</li> </ul>

Stop any activity where safety might be compromised whether it is your event or another.

## EXAMPLE

A pre-competition risk assessment has been conducted in relation to a javelin competition which is one event in a full track and field league fixture. Although the edge of the landing sector is in close proximity to the edge of the track previous league results suggest that the furthest distance that would be thrown at the event would be 45metres which would leave an ample "safety zone" between the infield area and the track.

However, on the day of competition you become aware that one club has entered a 60 metre plus Javelin thrower and that there are strong gusts of wind that have the potential to blow a javelin "off course".

As a field referee for the javelin event – what dynamic risk assessment would you carry out and what control measures could you put in place to mitigate any risks?

Some control measures that could be considered include:

- Timetable the Javelin competition at a time when no track events are taking place and widen the safety cordon
- Switch the Javelin throw to an alternative runway if this presents a safer option
- Inform the 60metre plus thrower that unfortunately they will not be able to throw for safety reasons.

# AN OFFICIAL'S SAFETY ROLE AT COMPETITIONS

As stated in the previous section all officials appointed to an event have a legal obligation to provide a reasonable, prudent and professional duty of care during a competition. The word “professional” in this context places a responsibility on officials’ to check that equipment and facilities are in good order before use, and that they are following recognised safe practices.

By the very nature of their role, Officials are always in close contact with athletes and should always remember that the main focus of athletes is to perform and not necessarily to secure the safety of their own immediate environment.

As well as controlling their own specific competition areas, officials should always be aware of other track and field events taking place within the arena, particularly those in the immediate vicinity; whether that be that infield throws landing areas, horizontal/vertical jumps runways/ landing pits or sprint and oval track lanes.

## KEY ROLES OF OFFICIALS AT EVENTS

- Conduct dynamic risk assessments throughout the duration of the event
- Control competition areas at all times from warm-up to event completion
- Lead by example particularly in the area of safety
- Audit the adequacy of the equipment, implements and the facilities to be used in the competition, including lighting if it is to be used
- Ensure the safety of fellow officials, athletes, coaches and spectators in and around the event through a constant awareness of what is happening around them and how it might impact on what they are doing
- Report any safety concerns immediately to those responsible
- Remain alert at all times, not just at the designated event but also of any adjacent activities that may have an impact
- Always look in both directions before crossing the track, sector/infield or any runway to ensure that it is safe to do so
- If officiating in the infield be alert to all implements at all times
- Never enter throwing impact areas unless the officiating role involves marking throws or retrieving implements
- Contact meeting management if they are not comfortable with safety in any situation
- Staying out of infield areas unless permitted to be there
- Immediately notify meeting management of any accidents, injuries or near misses

**Note:** It is important that officials decline any role they are incapable of or uncomfortable with, and request alternative duties. Note: Referees/Chiefs should take care to only assign officials to roles in which they have relevant experience and competence.

**Note:** For further information on specific roles and responsibilities of officials please review Appendix 3 of the UKA rulebook

BEFORE THE EVENT	WARM-UP	DURING THE EVENT
<ul style="list-style-type: none"> <li>■ Check all javelins before starting warm up and have the field retriever check them each time they return.</li> <li>■ Ensure that there are adequate retrievers and officials to oversee athlete warm up.</li> <li>■ Prior to the competition (before warm up), all competitors should be made aware of the safety procedures.</li> </ul>	<ul style="list-style-type: none"> <li>■ Officials should never stand nearer than 2metres to the netting when throwing is taking place.</li> <li>■ Officials must never turn their back on the throwing athlete.</li> <li>■ An event official should retrieve all throws and athletes should not be allowed to retrieve their own implements.</li> <li>■ Always keep the impact area clear during warm ups</li> <li>■ During the warm up the Field Referee should observe distances thrown and how the javelin reacts to the landing area and adjust official's positioning accordingly. For example: dry, hard infields will cause implements to bounce.</li> <li>■ Event officials should carry and not throw implements to the side.</li> <li>■ Implements must only be returned by hand, held vertically, or by mechanical device.</li> <li>■ Officials should not run within the throwing sector in wet, slippery conditions.</li> <li>■ For seated javelin throw follow the same procedures as for seated club throw (see page 35).</li> </ul>	<ul style="list-style-type: none"> <li>■ Throws must not commence until the supervising official signals to the athlete that it is safe to throw.</li> <li>■ Once the throw has been taken and the measurement recorded the procedure is repeated for each athlete throughout the competition.</li> <li>■ Officials responsible for marking long throws must be particularly vigilant when facing the sun and wear a cap or hat if appropriate.</li> <li>■ Officials should not run within the throwing sector in wet, slippery conditions.</li> <li>■ Once the throw has been taken and the measurement recorded the procedure is repeated for each athlete throughout the competition.</li> <li>■ When approaching a thrown javelin to mark the point of landing, or retrieve it, officials must approach the javelin from the side and not from the pointed tail end of the implement.</li> <li>■ Implement must only be returned by hand, held vertically, or by mechanical device.</li> <li>■ Be aware of the effect of strong winds on the flight characteristics of a javelin in flight.</li> <li>■ It is good practice to repair divots in the landing sector.</li> <li>■ For seated javelin throw follow the same procedures as for seated club throw (see page 35).</li> </ul>

**Stop any activity where safety might be compromised whether it is your event or another.**

# SAFETY PROCEDURES FOR JAVELIN THROW

(INCLUDING SEATED JAVELIN)

## FACILITY/EQUIPMENT SAFETY

1. The javelin, like the discus throw is affected by aerodynamics and the wind which means that the impact area can be very large. Wind direction should be considered when placing the roped area outside the sector lines. A javelin that lands flat on a hard surface can “skid” for a long distance and, when in doubt, the safety rope should be placed as far outside the sector lines as possible.
2. Event organisers, meeting managers and referees should ensure that Javelin throwing events are programmed so as not to present a hazard to other events.
3. Where long, triple or pole vault runways are located on the infield Javelin throwing must not take place unless a separate risk assessment indicates that the standard of throwers will pose no risk to jumpers.

BEFORE THE EVENT	WARM-UP	DURING THE EVENT
<ul style="list-style-type: none"> <li>▪ Ensure that all event Officials are given a safety briefing prior to the commencement of the event.</li> <li>▪ The meeting manager or organiser should ensure that all personnel who are liable to enter the infield are made aware of all safety considerations.</li> <li>▪ At least two of the event judges should be suitably qualified.</li> <li>▪ If persons who are not suitably qualified are used they must be taken to one side and instructed in the safety procedures before the start of their duties.</li> <li>▪ Where track kerbing is in the run up line, ensure that it is removed before the event, placed in a safe area, and replaced after the event. † (Note: not applicable to seated javelin)</li> <li>▪ If a hammer cage is used for seated javelin, ensure that both gates are locked in the open position.</li> <li>▪ UK Athletics approved Tie-down Devices must be used to conduct seated javelin throws</li> </ul>	<ul style="list-style-type: none"> <li>▪ Ensure ALL practice throws take place from †the runway under the supervision of a suitably qualified and competent official.</li> <li>▪ Warm-ups need to be well organised. For example having throwers warm up in competition order.</li> <li>▪ Javelin throwers should not be allowed to “spike” or throw practice throws outside the competition area.</li> <li>▪ The event leader MUST sound a warning horn to alert other officials that a throw is imminent. It must be emphasised to the athletes in the pre event briefing that the warning horn is to warn those within or in the vicinity of the throwing sector that a throw is about to commence and is not a signal for them to commence throwing.</li> <li>▪ In the case of the longer throwers allow 4 or 5 athletes to take their turns and then have officials pick up the implements and return them.</li> </ul>	<ul style="list-style-type: none"> <li>▪ Ensure ALL practice throws take place from †the runway under the supervision of a suitably qualified and competent official.</li> <li>▪ Officials in the field must be out of the sector during throws. Officials at †the runway need to be safely positioned.</li> <li>▪ Never stand behind a javelin thrower, they bring the javelin back before going forward, the back-end of a javelin can inflict a serious injury.</li> <li>▪ Competitors should be called up in 2s or 3s i.e. Number 15 to throw, 27 to get ready, nine to follow etc.</li> <li>▪ The Chief Judge must first check that the runway is clear.</li> <li>▪ The official must stand on the runway while the athlete takes up their starting position.</li> <li>▪ The Chief Judge must sound a warning horn to alert other officials that a throw is imminent.</li> <li>▪ When all officials and other personnel in the danger zone have acknowledged the sounding of the horn the athlete should be permitted to take up position on the runway</li> </ul>

CONTINUED

Stop any activity where safety might be compromised whether it is your event or another.

# WARM UP

# WARM-UP

Athlete pre-event warm-ups are a time when accidents are more likely to occur because multiple athletes tend to “share” use of available venue space simultaneously. Athletes will be focused on their own preparation during warm-up periods and there can be a risk that officials are less vigilant during this period than during formal competition.

There is also a risk that an official will focus purely upon the safety of athletes in the event they are controlling. Given the nature of track and field athletics and the wide range of activity that takes place within a relatively small area, this is potentially dangerous and officials should always ensure that they are aware of dangers posed by other events in order to protect the safety of both athletes and themselves.

## Athlete warm-up safety guidance

Officials and event organisers can help to ensure safe, well managed warm ups by implementing the following best practice:

- Ensure that field event warm-ups are supervised and controlled at all times
- Pre warn athletes of important warm-up safety protocols, for example:
  - One way systems
  - Specific Hurdle Lanes or Hurdle Only Areas
  - Designated event warm-up times
  - No headphones within the main arena
- Warm-ups should not be permitted in any areas deemed unsafe, including:
  - Other event warm-up areas
  - Spectator areas
  - “Live” competition areas
  - Slippery surfaces, banking, car parks etc

## ACTIVITY SAFETY

BEFORE THE EVENT	WARM-UP	DURING THE EVENT
<ul style="list-style-type: none"> <li>▪ Ensure that all event Officials are given a safety briefing prior to the commencement of the event.</li> <li>▪ The meeting manager or organiser should ensure that all personnel who are liable to enter the infield are made aware of all safety considerations.</li> <li>▪ At least two of the event judges should be suitably qualified.</li> <li>▪ If persons who are not suitably qualified are used they must be taken to one side and instructed in the safety procedures before the start of their duties.</li> <li>▪ UK Athletics approved Tie-down devices must be used to conduct seated throwing events.</li> <li>▪ If a hammer cage is used ensure that both gates are locked in the open position.</li> <li>▪ Check all clubs before starting warm up and have the field retriever check them each time they return.</li> <li>▪ Ensure that there are adequate retrievers and officials to oversee athlete warm up.</li> <li>▪ Prior to the competition (before warm up), all competitors should be made aware of the safety procedures.</li> </ul>	<ul style="list-style-type: none"> <li>▪ Ensure ALL practice throws take place from the circle, within an IAAF/UKA compliant Hammer or Discus cage, and under the supervision of a suitably qualified and competent official.</li> <li>▪ Warm-ups need to be well organised.</li> <li>▪ Each athlete must be strapped in an appropriate chair/throws frame. Once the chair/frame is secure an official will present the athlete with a club and clearly instruct them not to throw until BOTH a warning horn for officials AND a verbal instruction to them that it is safe to throw have been given. The official should check with the athlete that these instructions have been heard and understood.</li> <li>▪ The official must then vacate the internal cage area and there should be no-one else inside the cage except the throwing athlete.</li> <li>▪ The event leader MUST then sound a warning horn to alert other officials that a throw is imminent. It must be emphasised to the athletes in the pre event briefing that the warning horn is to warn those within or in the vicinity of the throwing sector that a throw is about to commence and is not a signal for them to commence throwing.</li> <li>▪ Once the official is happy that officials are prepared and the area is safe a verbal instruction to throw can be given to the athlete.</li> <li>▪ The athlete will then be allowed two practice throws and two further competition throws. The same safety processes must be followed for each and every throw.</li> <li>▪ Officials should never stand nearer than 2metres to the netting when throwing is taking place.</li> <li>▪ Officials must never turn their back on the throwing athlete.</li> <li>▪ An event official should retrieve all throws.</li> <li>▪ Always keep the impact area clear during warm ups</li> <li>▪ During the warm up the Field Referee should observe distances thrown and how the club reacts to the landing area and adjust officials positioning accordingly. For example: dry, hard infields will cause implements to bounce.</li> <li>▪ Event officials should carry implements to the side.</li> <li>▪ Implements must only be returned by hand, held vertically, or by mechanical device.</li> <li>▪ Officials should not run within the throwing sector in wet, slippery conditions.</li> </ul>	<ul style="list-style-type: none"> <li>▪ Ensure that all throws take place from the circle, within an IAAF/UKA compliant cage, and under the supervision of a suitably qualified and competent official.</li> <li>▪ Officials in the field must be out of the sector during throws. Officials at the circle or runway need to be safely positioned away from the cage.</li> <li>▪ The Chief Judge/Event Leader must first check that the circle is clear.</li> <li>▪ Ensure that only officials are allowed forward of the mouth of the throwing cage.</li> <li>▪ The event leader MUST sound a warning horn to alert other officials that a throw is imminent. It must be emphasised to the athletes in the pre event briefing that the warning horn is to warn those within or in the vicinity of the throwing sector that a throw is about to commence and is not a signal for them to commence throwing.</li> <li>▪ When all officials and other personnel in the danger zone have acknowledged the sounding of the horn the Chief Judge will verbally instruct the athlete that it is safe for them to commence their throw..</li> <li>▪ Officials responsible for marking throws must be particularly vigilant when facing the sun and wear a cap or hat if appropriate.</li> <li>▪ Officials should not run within the throwing sector in wet, slippery conditions.</li> <li>▪ Event officials should carry implements to the side.</li> <li>▪ Implements must only be returned by hand, held vertically, or by mechanical device.</li> <li>▪ It is good practice to repair divots in the landing sector.</li> </ul>

Stop any activity where safety might be compromised whether it is your event or another.

# SAFETY PROCEDURES FOR CLUB THROW

## FACILITY/EQUIPMENT SAFETY

1. Most accidents occur in the club throw for two main reasons.
  - a. The control of the club upon release is difficult, especially for beginners.
  - b. The club continues to travel on the landing area after impact. Although serious injury is not always a factor, broken ankles and other serious lower limb injuries can occur. Hard infield areas can compound this situation and a discus landing on this type of surface will tend to jump/skid for longer distances. Officials and athletes must be aware of this situation and when infield areas are hard/greasy roped off sections should extend to areas where the club can safely “skid” and come to rest.
2. For club throw events a protective cage is a vital part of the safety equation. However, not all cages conform to UKA regulations and some old specification cages (pre 2004), are often not high enough to contain errant throws.
3. On all cages the netting should have enough “give” in it to retard the force of the implement. However, the “give” in the netting can lead to injury if officials/athletes position themselves too close to the cage netting.
4. There are examples of when cage netting has had holes or weaknesses and implements have travelled through even the smallest openings and caused serious injury to officials and spectators. When netting is tied back too tightly or looped over tied downs the energy absorbing characteristics of the net are compromised and can cause implements to “rebound” inwards towards the athlete.
5. In order to ensure the continued integrity of the safety cage, the venue should ensure that the cage and netting is inspected by an accredited sports equipment safety consultant (e.g. RoSPA) at least every 12 months. *(Prior to the competition it is good practice for the Event Organiser to confirm with the venue that a recent cage/netting check has been carried out).*
6. Flags/ropes should be placed well outside the sector lines and spectators and media (photographers/cameramen) should be kept well outside the sector area.
7. Event organisers, meeting managers and referees should ensure that club throwing events are programmed so as not to present a hazard to other events.
8. Where long, triple or pole vault runways are located on the infield the club throw **must not** take place unless a separate risk assessment indicates that the standard of throwers will pose no risk to jumpers.

# TRACK SAFETY

# SAFETY PROCEDURES FOR TRACK EVENTS

Whilst track events may not appear to carry the same dangers as field events, athletes moving at speed in environments cluttered by potential hazards, fellow athletes, officials, kerbs, hurdles, barriers etc mean that serious accidents can and have occurred.

Robust pre-event facility and equipment checks alongside careful activity management will help to ensure that these hazards can be mitigated and a safe environment can be created for all involved.

## THE START

Officials working at the start line should ensure that athletes participating in a race can do so without coming in contact with another athlete or person. Responsibility for this lies with the official/starter responsible for the race start.

## THE FINISH

The finish line of a race has similar responsibilities imposed on the official(s) as at the start of the race. Again, athletes must be assured of a finish line that is unobstructed by individuals not competing in the race. At least one official should have responsibility for safety at the finish line.

## HURDLES

Hurdles should be made of metal with the top cross-bar of wood or other suitable material, with 2 feet and 2 uprights supporting the cross-bar.

Track officials should ensure that ALL hurdles are:

- In good condition (any damaged hurdles should be removed from use and marked for repair/disposal)
- Correctly set at the required height and toppling weights
- Positioned on the correct track markings for the event and not overlapping
- Facing in the right direction. Note: Hurdles have stripes or markings on one side. These stripes or markings must always face the athlete.

FIG. 1.0 HURDLE SPECIFICATION AND LAYOUT

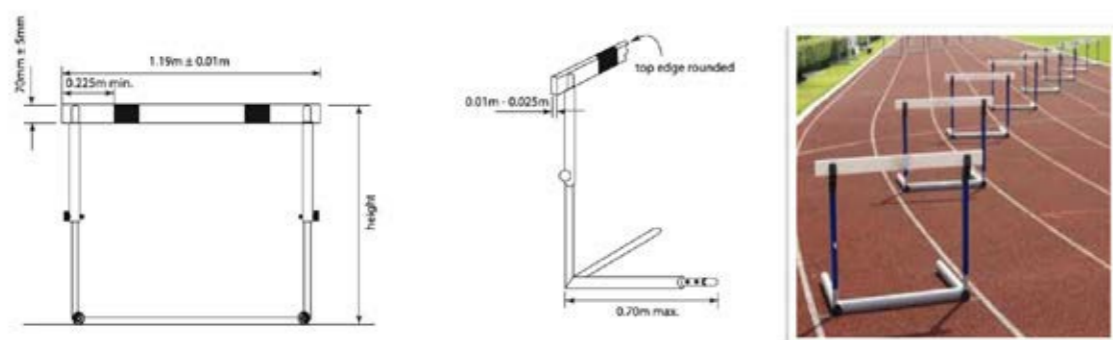

## ACTIVITY SAFETY

BEFORE THE EVENT	WARM-UP	DURING THE EVENT
<ul style="list-style-type: none"> <li>■ Ensure that all event Officials are given a safety briefing prior to the commencement of the event.</li> <li>■ The meeting manager or organiser should ensure that all personnel who are liable to enter the infield are made aware of all safety considerations.</li> <li>■ At least two of the event judges should be suitably qualified.</li> <li>■ If persons who are not suitably qualified are used they must be taken to one side and instructed in the safety procedures before the start of their duties.</li> <li>■ If a hammer cage is used ensure that both gates are locked in the open position throughout the event.</li> <li>■ Check all discus before starting warm up and have the field retriever check them each time they return.</li> <li>■ Ensure that there are adequate retrievers and officials to oversee athlete warm up.</li> <li>■ Prior to the competition (before warm up), all competitors should be made aware of the safety procedures.</li> </ul>	<ul style="list-style-type: none"> <li>■ Ensure ALL practice throws take place from the circle, within an IAAF/ UKA compliant cage, and under the supervision of a suitably qualified and competent official.</li> <li>■ Ensure that all event Officials are given a safety briefing prior to the commencement of the event.</li> <li>■ The meeting manager or organiser should ensure that all personnel who are liable to enter the infield are made aware of all safety considerations.</li> <li>■ At least two of the event judges should be suitably qualified.</li> <li>■ If persons who are not suitably qualified are used they must be taken to one side and instructed in the safety procedures before the start of their duties.</li> <li>■ If a hammer cage is used ensure that both gates are locked in the open position throughout the event.</li> <li>■ Check all discus before starting warm up and have the field retriever check them each time they return.</li> <li>■ Ensure that there are adequate retrievers and officials to oversee athlete warm up.</li> </ul>	<ul style="list-style-type: none"> <li>■ Ensure that all throws take place from the circle, within an IAAF/UKA compliant cage, and under the supervision of a suitably qualified and competent official.</li> <li>■ Officials in the field must be out of the sector during throws. Officials at the circle or runway need to be safely positioned away from the cage.</li> <li>■ Competitors should be called up in 2s or 3s i.e. Number 15 to throw, 27 to get ready, nine to follow etc.</li> <li>■ The Chief Judge/Event Leader must first check that the circle is clear.</li> <li>■ Ensure that only suitably qualified officials are allowed forward of the mouth of the throwing cage.</li> <li>■ The Chief Judge must stand with the athlete at the entrance to the cage.</li> <li>■ The event leader MUST sound a warning horn to alert other officials that a throw is imminent. It must be emphasised to the athletes in the pre event briefing that the warning horn is to warn those within or in the vicinity of the throwing sector that a throw is about to commence and is not a signal for them to commence throwing.</li> <li>■ When all officials and other personnel in the danger zone have acknowledged the sounding of the horn the Chief Judge will permit the athlete to take up their position in the circle to commence their throw and the time will begin at this point.</li> <li>■ Officials should never stand nearer than 2metres to the netting when throwing is taking place.</li> <li>■ Officials responsible for marking long throws must be particularly vigilant when facing the sun and wear a cap or hat if appropriate.</li> <li>■ Officials should not run within the throwing sector in wet, slippery conditions.</li> <li>■ Event officials should carry implements to the side.</li> <li>■ Implements must only be returned by hand, held vertically, or by mechanical device.</li> <li>■ Once the throw has been taken and the measurement recorded the procedure is repeated for each athlete throughout the competition.</li> <li>■ It is good practice to repair divots in the landing sector</li> </ul>

Stop any activity where safety might be compromised whether it is your event or another.

# SAFETY PROCEDURES FOR DISCUS THROW

(INCLUDING SEATED DISCUS)

## FACILITY/EQUIPMENT SAFETY

1. Most accidents occur in the discus for the following three reasons.
  - a. The aerodynamic design of the discus allows it to be affected by the wind, which causes the impact area to become extremely large during windy conditions.
  - b. The control of the discus upon release is difficult, especially for beginners
  - c. The discus continues to travel on the landing area after impact. Although serious injury is not always a factor, broken ankles and other serious lower limb injuries can occur. Hard infield areas can compound this situation and a discus landing on this type of surface will tend to jump/skid for longer distances. Officials and athletes must be aware of this situation and when infield areas are hard/greasy roped off sections should extend to areas where the discus can safely “skid” and come to rest.
2. For discus events a protective cage is a vital part of the safety equation. However, not all cages conform to UKA regulations and some old specification cages (pre 2004), are often not high enough to contain errant throws.
3. On all cages the netting should have enough “give” in it to retard the force of the implement. However, the “give” in the netting can lead to injury if officials/athletes position themselves too close to the cage netting.
4. There are examples of when cage netting has had holes or weaknesses and implements have travelled through even the smallest openings and caused serious injury to officials and spectators. When netting is tied back too tightly or looped over tied downs the energy absorbing characteristics of the net are compromised and can cause implements to “rebound” inwards towards the athlete.
5. In order to ensure the continued integrity of the safety cage, the venue should ensure that the cage and netting is inspected by an accredited sports equipment safety consultant (e.g. RoSPA) at least every 12 months. *(Prior to the competition it is good practice for the Event Organiser to confirm with the venue that a recent cage/netting check has been carried out).*
6. Flags/ropes should be placed well outside the sector lines and spectators and media (photographers/cameramen) should be kept well outside the sector area.
7. Event organisers, meeting managers and referees should ensure that discus throwing events are programmed so as not to present a hazard to other events.
8. Where long, triple or pole vault runways are located on the infield discus throwing **must not** take place unless a separate risk assessment indicates that the standard of throwers will pose no risk to jumpers.

# STEEPLECHASE

Officials should check steeplechase hurdles and the water jump barrier and make sure that they are all stable, set at the correct height, free from damage/splinters and capable of withstanding the weight of several athletes jumping on and off at the same time.

The water jump should be full (water level with track surface), and free from all debris. The floor of the water jump must be smooth and fully covered by a synthetic track surface in order to ensure that athletes have sufficient cushioning and grip to land safely.

When located in and around the field of play the water jump supply tap must be protected by a stable, well-fitting manhole cover in order to prevent unauthorised use and a risk of trip/fall injury to athletes and officials.

Prior to the race Officials should check that athletes are wearing appropriate footwear (ideally spikes), in order to prevent slips/falls on barrier tops.

Removable kerbs should be in place except for the approach to, and exit from, the water jump, where all protruding edges should be covered and sections securely fixed down. In the vicinity of the water jump small cones must be used to provide track edge markings until water jump comes into use in competition. When not in use cones and removable kerbs should be stored safely away from athletes and officials.

FIG. 2.0 STEEPLCHASE BARRIERS

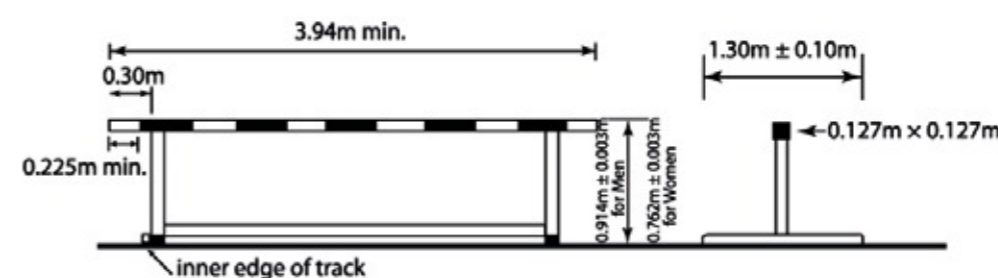
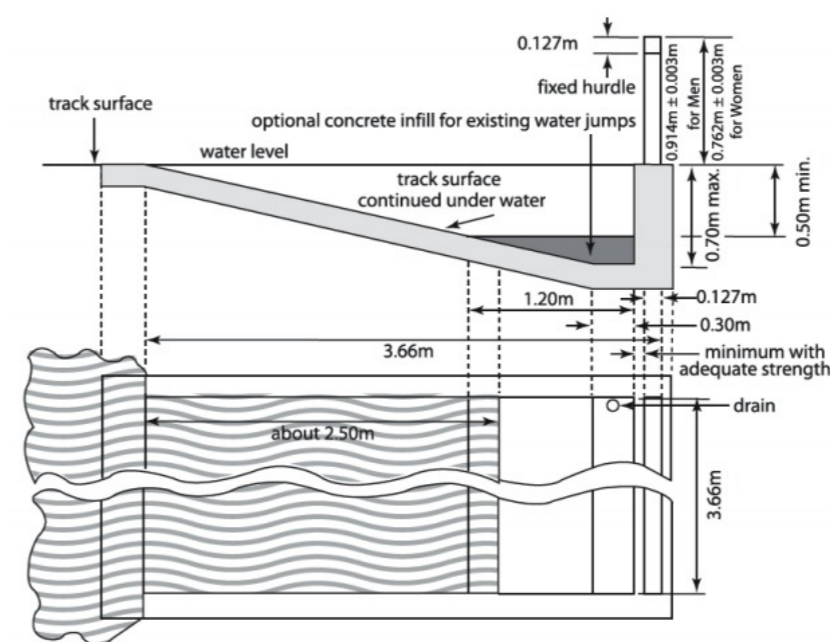

FIG. 3.0 STEEPLCHASE WATER JUMP



# STARTING SAFETY

## ACTIVITY SAFETY

BEFORE THE EVENT	WARM-UP	DURING THE EVENT
<ul style="list-style-type: none"> <li>Ensure that all event Officials are given a safety briefing prior to the commencement of the event.</li> <li>The Meeting Manager or Organiser should ensure that all personnel who are liable to enter the infield are made aware of all safety considerations.</li> <li>At least two of the event judges should be suitably qualified.</li> <li>If persons who are not suitably qualified are used they must be taken to one side and instructed in the safety procedures before the start of their duties.</li> <li>Check that both hammer cage gates/curtains are fully functional and can be securely locked in position for both left and right handed throwers.</li> <li>Check all hammers before starting warm up and have the field retriever check them each time they return.</li> <li>Ensure that there are adequate retrievers and officials to oversee athlete warm up.</li> <li>Check all Hammers before starting warm up and have the field retriever check them each time they return.</li> <li>Prior to the competition (before warm up), all competitors should be made aware of the safety procedures.</li> </ul>	<ul style="list-style-type: none"> <li>Ensure ALL practice throws take place from the circle, within an IAAF/ UKA compliant cage, and under the supervision of a suitably qualified and competent official.</li> <li>Ensure both cage gates are correctly positioned and locked before each throw in accordance with UKA rules, in particular that the gates are correctly set for right and left handed hammer throws.</li> <li>Warm-ups need to be well organised, e.g. having throwers warm up in competition order.</li> <li>The event leader MUST sound a warning horn to alert other officials that a throw is imminent. It must be emphasised to the athletes in the pre event briefing that the warning horn is to warn those within or in the vicinity of the throwing sector that a throw is about to commence and is not a signal for them to commence throwing.</li> <li>In the case of the longer throwers allow 4 or 5 athletes to take their turns and then have official's pick up the implements and return them.</li> <li>Officials should never stand nearer than 2metres to the netting when throwing is taking place.</li> <li>Officials must never turn their back on the throwing athlete.</li> <li>An event official should retrieve all throws and athletes should not be allowed to retrieve their own implements.</li> <li>Always keep the impact area clear during warm ups.</li> <li>During the warm up the Field Referee should observe the distances thrown and how the hammer reacts to the landing area and adjust official's field positioning accordingly. For example: dry, hard infields will cause implements to bounce.</li> <li>Event officials should carry and implements to the side.</li> <li>Implements must only be returned by hand, held vertically, or by mechanical device.</li> <li>Officials should not run within the throwing sector in wet, slippery conditions.</li> </ul>	<ul style="list-style-type: none"> <li>Ensure that all throws take place from the circle, within an IAAF/UKA compliant cage, and under the supervision of a suitably qualified and competent official.</li> <li>Ensure both gates are correctly positioned and locked before each throw in accordance with UKA rules, in particular that the gates are correctly set for right and left handed hammer throws.</li> <li>Officials in the field must be out of the sector during throws. Officials at the circle or runway need to be safely positioned away from the cage.</li> <li>Competitors should be called up in 2s or 3s i.e. Number 15 to throw, 27 to get ready, nine to follow etc.</li> <li>The Chief Judge/Event Leader must first check that the circle is clear.</li> <li>Ensure that only suitably qualified officials are allowed forward of the mouth of the throwing cage.</li> <li>The Chief Judge must stand with the athlete at the entrance to the cage.</li> <li>The event leader MUST sound a warning horn to alert other officials that a throw is imminent. It must be emphasised to the athletes in the pre event briefing that the warning horn is to warn those within or in the vicinity of the throwing sector that a throw is about to commence and is not a signal for them to commence throwing.</li> <li>When all officials and other personnel in the danger zone have acknowledged the sounding of the horn the Chief Judge will permit the athlete to take up their position in the circle to commence their throw and the time will begin at this point.</li> <li>Officials responsible for marking long throws must be particularly vigilant when facing the sun and wear a cap or hat if appropriate.</li> <li>Officials should not run within the throwing sector in wet, slippery conditions.</li> <li>Event officials should always carry implements to the side.</li> <li>Implements must only be returned by hand, held vertically, or by mechanical device.</li> <li>Once the throw has been taken and the measurement recorded the procedure should be repeated</li> <li>It is good practice to repair divots in the landing sector</li> </ul>

Stop any activity where safety might be compromised whether it is your event or another.

## THROWING SAFETY ESSENTIALS

1. Rotational throwing events (Hammer, Discus, Club and Weight Throw) MUST ALWAYS take place from within a compliant and fit for purpose safety cage.
2. Only the athlete throwing the implement should be permitted into the cage/circle during a throw.
3. When officiating at venues with throws facilities ALL officials (regardless of the event they are officiating), must remain alert to any throws activity that is taking place, even when this is conducted in areas with a safety cage.
4. Officials MUST NEVER turn their back on a throws cage/circle or javelin runway.
5. Those officiating in infield areas must be suitably qualified, be able to move quickly in all directions and have good eyesight, hearing, balance and mobility.
6. † A warning horn MUST be used for all hammer, discus, javelin, club and weight throws, both during warm up and competition.
7. If portable cages are used these MUST be IAAF approved, installed by a competent person/company in accordance with manufacturer instructions, and cross checked both during and post installation by an independent and competent safety advisor.
8. For their own safety and that of others, coaches and officials should always follow the throws safety guidance contained within this safety guide.

† The ONLY exception to this is for competitions broadcast by Television where event-specific safety procedures have been introduced to ensure the safety of all participants and officials.

## SAFETY PROCEDURES FOR HAMMER THROW

### FACILITY/EQUIPMENT SAFETY

1. For hammer events a protective cage is a vital part of the safety conditions. However, not all cages conform to UKA regulations and some old specification cages (pre 2004), are often not high enough to contain errant throws.
2. On all cages the netting should have enough “give” to retard the force of the implement. However, the “give” in the netting can lead to injury if officials/athletes position themselves too close to the cage netting.
3. There are examples of cage netting having holes or weaknesses and implements having travelled through even the smallest openings and causing serious injury to officials and spectators. When netting is tied back too tightly or looped over tie-downs the energy absorbing characteristics of the net are compromised and can cause implements to “rebound” inwards towards the athlete.
4. In order to ensure the continued integrity of the safety cage, the venue should ensure that the cage and † netting is inspected by an accredited sports equipment safety consultant (e.g. RoSPA) at least every 12 months. (Prior to the competition it is good practice for the Event Organiser to confirm with the venue that a recent cage/netting check has been carried out).
5. Although “the hammer implement is” not affected as much by the wind as the discus and javelin, the hammer throw is still potentially a very dangerous event. The actual size of the implement is very large because, in addition to the hammer “ball”, the wire and handle “attachments” can also cause serious injury.
6. Flags/ropes should be placed well outside the sector lines and spectators and media (photographers/cameramen) should be kept well outside these markers.
7. Event organisers, meeting managers and referees should ensure that hammer throwing events are programmed so as not to present a hazard to other events.
8. Where long, triple or pole vault runways are located on the infield; hammer throwing **must not** take place unless a separate risk assessment indicates that the standard of throwers will pose no risk to jumpers.

## SAFETY PROCEDURES FOR STARTERS

Any firearm is potentially dangerous and careless or irresponsible handling can have very serious results. Every firearm should be viewed as being loaded unless it has been safely and clearly demonstrated that there is no ammunition present, i.e. that the gun is ‘proved’. This applies to firearms loaded with blank ammunition and the following guidance should be strictly adhered to at all times.

The use of a revolver for starting creates some safety aspects and although only blank cartridges are used, the wadding and powder are capable of causing serious injuries especially to the eyes.

### GENERAL CONSIDERATIONS

1. Alternatives to starting pistols (i.e. electronic gun system), should be used where possible/available.
2. Starters should wear protective devices on their ears to prevent prolonged exposure to loud noises that could damage hearing.
3. Starters should not wear starter jackets outside the track, or use a bag marked starter.
4. Starters must ensure that firearms are kept in their possession at all times and that they are never left on the rostrum or on other exposed and unprotected places.
5. When not in use, starters must keep firearms out of sight in a bag with other personal kit which shall be kept in their possession at all times.
6. If a privately loaded gun is used the volume should not exceed 140Db.
7. Starters should ensure that .45” cartridges are not used indoors and that the volume of a commercially produced 9mm cartridge is the limit.

### HANDLING A FIREARM

1. Unless in the process of starting a race the trigger of the firearm should not be touched and the muzzle should always be pointed downwards.
2. Dropping the gun should be avoided.
3. Firearms must never be pointed at anyone, loaded or otherwise.
4. Firearms should not be held close to the face.
5. Starters should never indulge in horseplay or joke around with firearms.
6. Guns should not be cocked until the starter is ready to commence the starting procedure.
7. Revolvers should always be broken open with care to avoid both used and unused cartridges being ejected in an uncontrolled fashion onto the ground where they can easily be lost.
8. Starters should be aware of obstructions in the barrel, e.g. a cartridge wad, which can result in a blowback or even a bulged barrel if not cleared.
9. Cartridges should not be tampered with.
10. If a firearm jams, it should be gripped carefully on the handle by the stronger hand with the barrel pointing downwards. The thumb of the opposite hand should be placed on the weight throw spur, pressing it back to its full extended position. The weight throw position should be held whilst the forefinger of the stronger hand gently squeezes the trigger whilst allowing the weight throw to slowly lower forward into an ‘uncocked’ position. **DO NOT ALLOW THE WEIGHT THROW TO GO FORWARD QUICKLY: TO DO SO MAY RESULT IN ANY CARTRIDGE IN THE CYLINDER OPPOSITE THE WEIGHT THROW BEING FIRED.** Once a jammed firearm has been released in this way, it is possible to open it safely in the normal fashion.

## GENERAL STARTING GUIDANCE

1. If safety ropes are adjusted for any purpose, they must be immediately replaced.
2. †Ensure that a loud blast is blown on a whistle before the start of each race or heat to indicate to the competitors that the race is about to start and also as a warning to everyone else.
3. Ensure that the starting gun is always fired straight up in to the air and the recall gun down to the ground.
4. Check that the ground in the vicinity is clear and that nobody has approached unnoticed.
5. Ensure that firearms are loaded carefully and that cartridges are not spilled onto the ground.
6. Ensure that empty cases are not discarded at a meeting and that they are collected up and disposed of as scrap metal or by some other reliable method.
7. Ensure that spent cases are never given away as souvenirs.

†Does not apply to televised events

## POST USAGE

1. Firearms should always be cleaned after use.
2. Following cleaning the Firearm should be oiled lightly, wrapped in a cloth, and stored in the manner approved by the Constabulary that issued the Firearm certificate.

## CABLED START INFORMATION SYSTEM

1. Position of starter's podium and start information system to be agreed prior to start of competition.
2. All cables should be laid in an orderly manner to each of the start blocks
3. The cables from the start blocks to the console should be laid in an orderly manner and routed to avoid as far as possible the 'normal' pathways of all personnel at the start.
4. Cables from the start console to the starter's podium should be laid in an orderly manner and secured as necessary to the podium.
5. Any audio system should be set at a comfortable position and noise level.
6. Electronic gun systems should be set up to the satisfaction of the starter.
7. Movement of start blocks and start information system when appropriate before and after a heat or final.

## WIRELESS START INFORMATION SYSTEM

1. Any audio system should be set at a comfortable position and noise level
2. Electronic gun systems should be set to the satisfaction of the starter.
3. Position of starter's podium and start information system to be agreed prior to start of competition.
4. Movement of start blocks and start information system when appropriate before and after a heat or final.

## JUDGING LONG THROWS (HAMMER, DISCUS, JAVELIN, CLUB)

In accordance with UKA Rules of Competition, officials cannot judge in the landing sector in any throwing event until they have completed a UKA Track & Field Health & Safety module.

In all cases of Long Throws the event must be controlled by a Chief Judge who is a qualified Technical Official at Level 2 or above. They may position themselves in the landing sector or be the controlling judge at the throwing area, depending on the distances likely to be thrown.

The following may judge within the [landing sector](#) :

- Qualified Technical Officials at Level 1 and above.

The following may [judge or assist outside the landing sector](#), entering the sector only after the implement has landed (e.g. as implement retrievers or Validity Judges).

- Qualified Technical Officials at Level 1 and above.
- UKA Assistant Officials who have attended a UKA Health & Safety course.
- Helpers over the age of 16 who have been fully briefed in the safety requirements of athletics events before competition commences by the Meeting Manager and / or Field Referee.

The following may only [judge or assist outside and behind the mouth of the throwing cage, or behind the scratch line of the javelin runway or circle](#). Example roles include; Circle/runway judge (there are several duties associated), pull-through tape, arm action, implement control, scoreboard, card judge, EDM operator, clock operator, Athletes' Steward

- UKA Assistant Officials who have not attended a UKA Health & Safety course.
- Helpers over the age of 16 who have not been fully briefed in safety requirements of athletics events before competition commences by the Meeting Manager and / or Field Referee.

**Note:** These requirements are applicable to ALL competitions held under UKA Rules at all levels (including leagues & open meetings)

# SAFETY IN THROWS

## OVERVIEW

All of the implements that are thrown at athletics training sessions and during competitions have the potential to be lethal weapons if their use is not properly managed and supervised at all times. Throwing events should always be properly managed and supervised and safety **MUST ALWAYS** come first. Impact or contact from an “in-flight” hammer, discus, club, javelin or shot will almost certainly result in a serious or fatal injury. As an event official it is **YOUR** responsibility to ensure that all competitions are conducted in a safe manner and it is imperative that the guidance contained in this manual is followed at all times.

To help avoid accidents the central throwing area or the specific safety sector must be roped off as a unit at a height of approximately 1 metre. Shot throwing sectors must be roped off at a height of approximately 1 metre and at a minimum distance of 2 metres outside the sector lines.

For safety reasons **ALL THROWS** should be preceded by a warning signal which shall be acknowledged by the event officials before the throw commences.

To ensure your own personal safety and that of participants **YOU MUST BE:**

## MENTALLY AND PHYSICALLY ALERT

Many of the serious injuries that have occurred during throwing events in the past have identified a lack of attentiveness by an official (s) as a major cause. The nature of the event dictates that throwing event officials must be extremely alert and concentrate on what and where they are, and where the athletes are at **ALL** times. Officials positioned in or near implement impact areas should ensure that they are aware of the abilities of the athletes so that they know who the long and potentially wayward throwers are and can adjust their position on the field accordingly.

## FOCUSED ON THE EVENT

It is vital that officials are fully focused on the event and remain undistracted by other activities. Field event programmes are fast moving and it is important that quick and accurate decisions and actions can be taken.

## AGILE

Those officiating in the infield must be able to move quickly in all directions and have good balance and mobility. In addition for their own personal safety all officials must have:

- Good eyesight in order to see implements in the air
- Good hearing so that they can hear the warning horn and any other warning signals

For those who officiate during throwing events it is essential to remain vigilant at all times as bystanders, spectators and even athletes are not always as aware of the dangers associated with their event. It is your responsibility to inform and educate them (sometimes firmly), both for their own safety and for your own peace of mind.

## COMPETITION TIMETABLE

When selecting venues and planning timetables meeting organisers should take into account all aspects of the day and endeavour to ensure that officials are not put in a position where they may become excessively tired. Enough officials should be appointed to the meeting to ensure that they can all have sufficient breaks during the day.

# PHOTO FINISH SAFETY

## SAFETY PROCEDURES FOR PHOTO FINISH

Technical Officials will usually set up Photo-Finish equipment themselves, but check at the planning stage what expectations are about how this will be done.

All photo finish systems work on similar principles, although they can appear very different, and may require differing approaches by the operator. The most common system in UK is FinishLynx. The Seiko system is almost identical, and the Swiss Timing/Omega system is very similar. Timetronics uses a slightly different method of operation.

All systems record a start time, capture an image of the finish, and store this data labelled as an identified race. From this the precise time of each finishing athlete is determined, and hence the finishing order. These times and places are then made available as the 'result' of the race.



# THROWS SAFETY

## FACILITY/EQUIPMENT SAFETY

### PHOTOFINISH TOWER

In the case of temporary scaffolding towers it is important to ensure that the tower is designed, erected, altered and dismantled only by competent people and in accordance with the manufactures instructions. Construction should always take place under the direction of a competent supervisor.

For permanent towers/fixtures ensure that a safety information plate is in place, legible and in date.

1. Ensure that Working at Height Regulations (2005) are followed and that a documented working at height risk assessment has been completed and control measures implemented where necessary.
2. Ensure that the working platform flooring is securely attached to the tower framework.
3. Ensure that the working platform safety rail is at the regulation height above the level of the platform floor, notwithstanding the camera's line of view.
4. Ensure that the tower is securely braced and stabilised against the ground environment.

## ACTIVITY SAFETY

BEFORE THE EVENT	WARM-UP	DURING THE EVENT
<ul style="list-style-type: none"> <li>Ensure that all athletes are wearing suitable footwear.</li> <li>Where possible flag/rope off run-up areas.</li> </ul>	<ul style="list-style-type: none"> <li>Confine warm-ups to safe, managed areas, usually on the runway(s). Pay particular attention during the warm-up period since the time between jumps is much shorter and attention may be diverted with multiple activities occurring.</li> <li>Do not let another jumper start their jump until the last jumper has cleared the pit.</li> <li>Rake the pit during warm up when the surface becomes rutted with deep holes or every 10 jumps.</li> <li>Rakes and brushes used for levelling and cleaning should be kept away from landing area and prongs of rakes should face the ground.</li> </ul>	<ul style="list-style-type: none"> <li>Do not let another jumper start their jump until the last jumper has cleared the pit.</li> <li>Do not cross run ways during a competition and keep your eye on the runway at all times.</li> <li>Caller and/or guides should stand in a safe place that does not impede the view of the officials.</li> <li>Rakes and brushes used for levelling and cleaning should be kept away from landing area and prongs of rakes should face the ground.</li> </ul>

Stop any activity where safety might be compromised whether it is your event or another.

- Ensure that access to the working platform is preferably from within the ground footprint of the scaffold tower.
- Ensure that the working platform access device is safe and secured to both the working platform and ground environment.
- Ensure that high visibility tape is wound around the lower tower extremities from ground level to a height of 2 metres.
- Ensure that the aperture through which the PF camera points towards the track has a suitable safety rail(s) to prevent PF operatives from falling on to structures below the camera location.
- Ensure that all PF technical officials are aware of the opening facility.

### TEMPORARY STAND ALONE VIDEO CAMERA MOUNTING TRI-POD

- Ensure that the tri-pod is securely positioned.
- Ensure that the tri-pod is of a contrasting colour to its surroundings.
- Ensure that when accessing the camera, an 'A' frame ladder is used suitably braced and steadied by a competent person.

### VIDEO PHOTO FINISH EQUIPMENT INSTALLATION

- Ensure that all mains power supply outlets have switches and power 'ON' indicators.
- Ensure that all mains power supply plugs and associated cables have in-date safety labels.
- Ensure that all electrical cables are routed away from the operating area and protected on the floor by rubber cable mats.

### AUTOMATIC STARTING DEVICE(S) INSTALLATION

- Ensure that all electrical cables are routed via dedicated cable ways, near to the inside of the inside track kerb and protected from athletes/general pedestrian traffic by rubber cable mats.
- Ensure that where no special provision is made for the egress of cables from manholes, notices are displayed warning of raised manholes.

### RESULTS CLIPS

- Ensure that the area below the PF operating position, in which a results clip is dropped, is cordoned and warning notices displayed.
- Ensure that the area below the PF operating position is clear of all personnel before a results clip is dropped.

## SAFETY PROCEDURES FOR LONG & TRIPLE JUMP

# JUMPS SAFETY

### FACILITY/EQUIPMENT SAFETY

1. The biggest safety factor in the long and triple jump is the proper preparation of the landing area.
2. For both warm-up and competition the sand should be:
  - a. Dug over and loosened to a minimum depth of at least 30 cm (measured 30 cm in from the edge of the pit). This is extremely important as compacted/shallow sand is the most frequent cause of injury.
  - b. Raked to create an even, level surface
3. The landing area itself should have a minimum width of 2.75 m and a maximum width of †3 m.
4. The minimum length of the runway, measured from the relevant take-off line shall be 40 m with a width of 1.22 m.
5. For Long Jump the distance between the take-off line and the far end of the landing area should be a minimum of 10 m.
6. For Triple Jump the distance between the Men's take-off line and the far end of the landing area should be a minimum of 21 m.
7. Take-off boards should be checked for excess wear and tear. It is important to make sure the take-off boards are close enough to the sand pit to meet the level of competition.
8. The edges of the landing areas should be covered with an impact-absorbing material and rounded off.
9. There should be no objects or obstructions within 1 metre of the sides of the runway/landing area and 2 metres to the rear of the landing area (See fig. 6.0)
10. When distance indicator boards are used these must be positioned at least 1 metre away from the edge of the landing area.
11. A 1 m x 1.22 m chalked square should be marked at the take-off for visually impaired athletes.

†The width of the landing area can be increased to 3.50 m for visually impaired athletes T11/T12

FIG. 6.0 LONG/TRIPLE JUMP SAFETY MARGINS

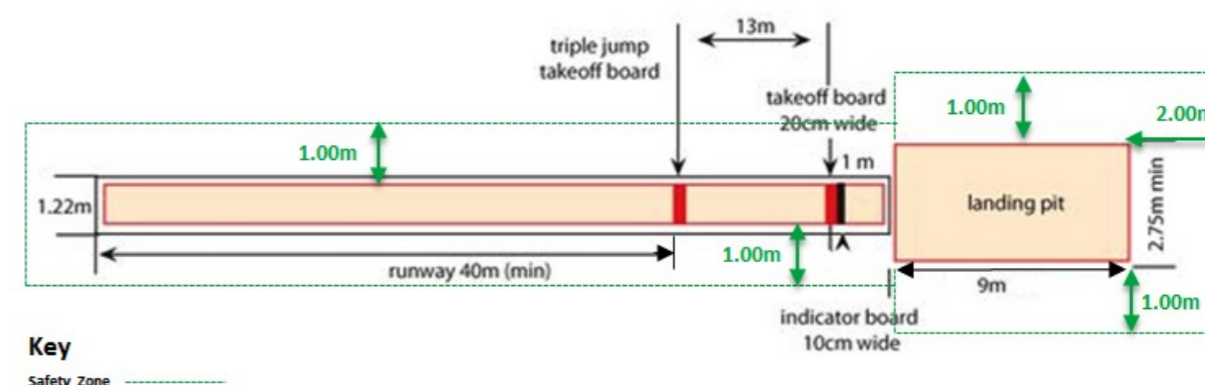

ACTIVITY SAFETY

BEFORE THE EVENT	WARM-UP	DURING THE EVENT
<ul style="list-style-type: none"> <li>Ensure that athletes are wearing suitable footwear.</li> </ul>	<ul style="list-style-type: none"> <li>Ensure each athlete jumps in turn and does not encroach on other athletes' run whilst waiting their turn.</li> <li>Make sure the landing beds and surrounding areas remain clear of items that might cause injury.</li> </ul>	<ul style="list-style-type: none"> <li>Ensure each athlete jumps in turn and does not encroach on other athletes' run whilst waiting their turn.</li> <li>If an athlete commences their approach run from the track the athlete and officials must be aware of the potential hazard from other track events.</li> <li>Continuously monitor the landing beds to make sure they aren't moving; readjust them as needed.</li> <li>Make sure the landing beds and surrounding areas remain clear of items that might cause injury.</li> </ul>

Stop any activity where safety might be compromised whether it is your event or another.

# SAFETY PROCEDURES FOR POLE VAULT

## FACILITY/EQUIPMENT SAFETY

- In terms of athlete safety the pole vault landing bed is extremely important. In recent years the required size and padding of the landing area has increased for safety reasons. Pre-event landing area and upright checks must be carried out to ensure that all aspects of the Pole Vault event are safe and compliant with the UKA rulebook.
- No vaulting should be allowed to commence unless ALL the pads and padding are in place. This includes padding around the box as well as the padding for the uprights.
- Bed units must be made of suitable foam and – if made up of several sections - must be securely fastened together. The entire area must be covered by an attached spike-proof wear sheet. No gaps or separations should exist.
- Landing beds should be 800mm in depth.
- Where landing beds are placed on other objects such as pallets, these should not be more than 100mm in height and must not protrude beyond the edges of the landing areas.
- Any hard surface from the centre of the box 5m to the front and sides and 7m to the rear must be covered with an impact absorbing material for a critical fall height of 1.5m or suitable additional matting, and must have no obstructions onto which an athlete might fall. (See fig 4.0 for safety margins for both 5m and 6m landing beds)
- Existing fences in the immediate vicinity of the landing area should be either re-located or covered in suitable padding.
- The front surface of the pallets beyond the box must be blocked off so that there is no possibility of the pole or athlete's foot penetrating underneath.
- Ensure that landing beds, extension pads and box surrounds are all the correct size and conform to current UKA Rules

FIG. 4.0 POLE VAULT LANDING AREA SPECIFICATION AND SAFETY MARGINS

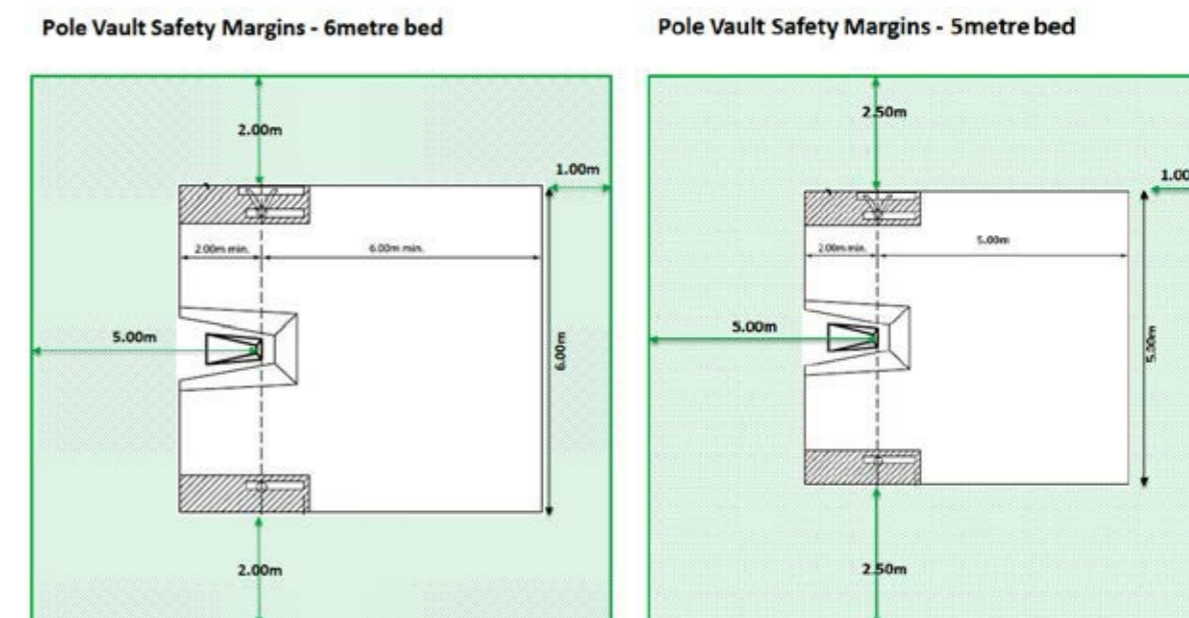

10. Winders and lower section of stands should be protected with foam or similar padding.
11. Uprights must be checked for loose wheels, broken or slipping tapes, securing pins/screws, winding handles, bar supports.
12. The base must be well secured, free from rust and lubricated.
13. When used droppers must be rigid and firmly fixed.
14. Examine runways to ensure there are no worn or damaged areas.
15. No obstructions or checkmarks should be placed on the runway.
16. When revolving scoreboards are used ensure they do not revolve over or are sited close to the runway, they must also be firmly anchored down.
17. All scoring stands, tables, chairs, vaulting box covers, or any other objects should be out of the area where, if the vaulter "stalls out" they cannot possibly come into contact with an object that could cause injury.
18. If a wind sock is available position it off the runway but near to the take off point to indicate the wind direction and strength at the point of take-off.
19. If a Pole Vault competition is to be held during the evening ensure that floodlighting does not cause glare and is adequate for the standard of competition.

#### ACTIVITY SAFETY

BEFORE THE EVENT	WARM-UP	DURING THE EVENT
<ul style="list-style-type: none"> <li>▪ Ensure that weather conditions are suitable for the activity.</li> <li>▪ If you are the head official at the pole vault or high jump, double check to ensure that the foam landing beds are securely buckled together prior to warm-up and during warm-up and competition.</li> <li>▪ Ensure vaulters are sufficiently competent to avoid injury to themselves and others. A track meeting should not be an unsupervised pole vault practice session for inexperienced athletes.</li> <li>▪ Monitor the zero point line and the marking on the pad to ensure they align.</li> </ul>	<ul style="list-style-type: none"> <li>▪ Ensure supervision of athletes during warm-up.</li> <li>▪ Care must be taken to ensure vaulting poles do not constitute a tripping hazard during warm-up and competition.</li> <li>▪ Ensure runway is kept clear when vaulters are about to start their approach.</li> <li>▪ Beware of falling poles.</li> <li>▪ Ensure run up is kept clear when athletes are waiting.</li> <li>▪ If a dedicated pole rack is not available poles should be located in a safe area and officials should ensure that poles do not protrude onto any track/runway areas.</li> </ul>	<ul style="list-style-type: none"> <li>▪ Regularly check poles for damage.</li> <li>▪ Beware of falling poles.</li> <li>▪ Ensure run up is kept clear when athletes are waiting.</li> <li>▪ Officials should ensure that poles do not protrude onto any track/runway areas.</li> </ul>

Stop any activity where safety might be compromised whether it is your event or another.

## SAFETY PROCEDURES FOR HIGH JUMP

### FACILITY/EQUIPMENT SAFETY

1. The landing bed is the most important safety item in the High Jump and practice or competition should never be allowed on a bed that does not meet current UKA specifications (L = 3m, W=5m, D=0.6m - See fig 5.0). It is important that all segments of the landing bed are properly attached together and that no gaps or separations exist. An overall wear sheet must be placed over the segments and secured.

FIG. 5.0 HIGH JUMP SAFETY MARGINS (5M X 3M UKA LANDING BED)

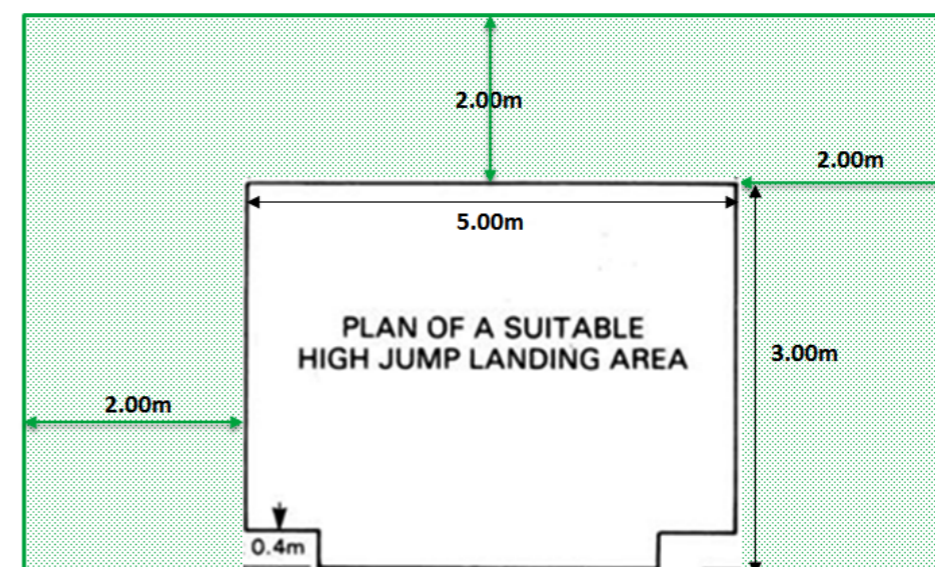

2. Bed units must be made of foam, securely fastened together and must conform in size to current UKA specifications. The entire area must be covered by an attached spike-proof wear sheet.
3. Where beds are placed on other objects - such as timber pallets - these should be not more than 100mm high and must not protrude beyond the edges of the landing areas. In addition the front surface of the pallets must be blocked off so that there is no possibility of an athlete's foot penetrating underneath.
4. Any hard surface within 2m of the sides and rear of the landing area must be covered with an impact-absorbing material with a critical fall height of 1.5m or suitable additional matting.
5. There should be no objects such as scoreboards placed within 2m of the sides and rear of the landing area.
6. Bases must be stable and joined onto the upright.
7. Crossbar supports should face each other and must be easily adjusted and level.
8. The high jump uprights and cross bars should be checked for stability to ensure that if a high jumper lands in the middle of the cross bar the uprights do not topple inward and cause injury.
9. The take-off / fan area should be checked, and any hazards removed (e.g. pin, tacks, tape).
10. In wet weather sponge rollers/brushes should be utilised to remove surface water and prevent slipping.
11. Any kerbing removed for competition must be stored safely.
12. Scoreboards anchored, previous check marks removed.